

DOCO[®]

INTERNATIONAL

part of your door

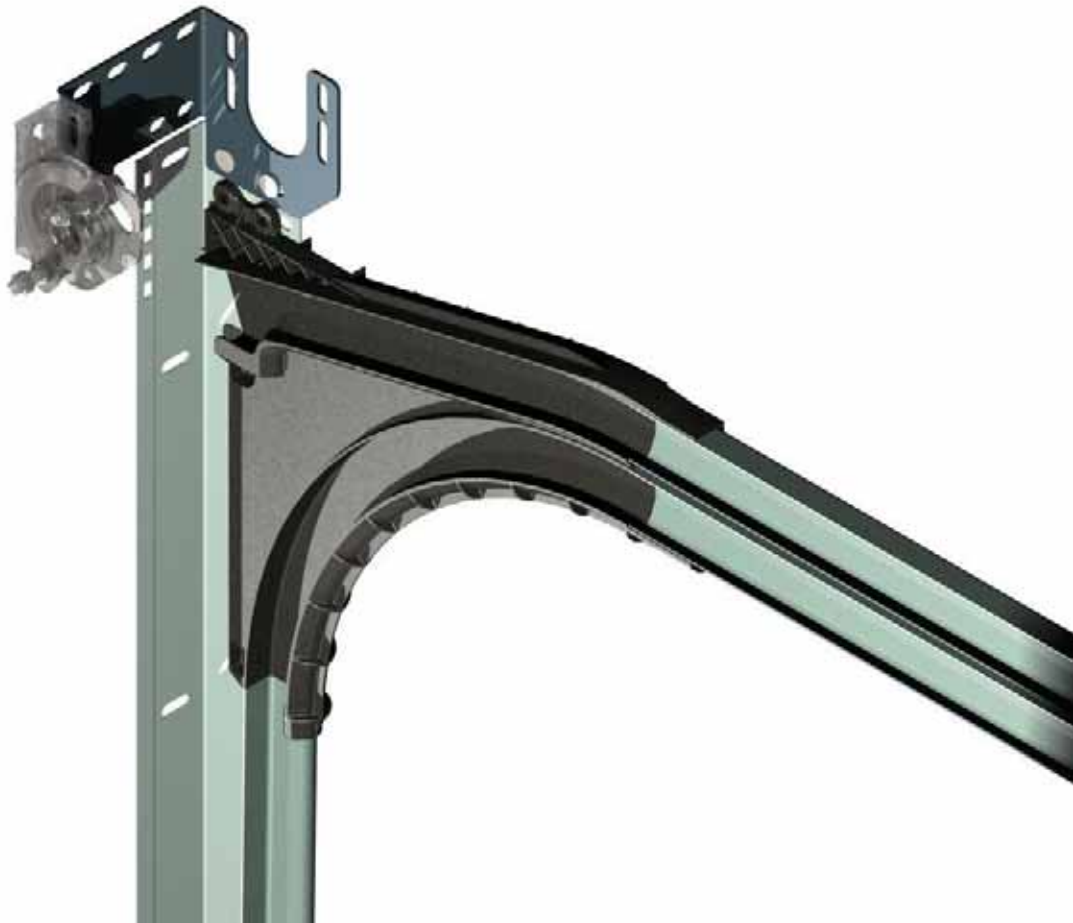

Manual

Sectional door with front springs (LF 220)
Conform TÜV / CE EN 13241-1

TÜV NORD CERT

CE

UK

Contents

1	Symbols and warning signs	3
2	General warnings	3
2.1	Safety requirements for assembly, first use and maintenance	3
3	Directives and standards	4
3.1	Guarantee and liability	4
4	Application + Testing	4
5	Assembly	5
5.1	Preparation of the assembly	5
5.2	Fixing materials and instructions	6
5.2.1	Mounting equipment and attachments	8
5.3	Mounting the angle lines and bends	9
5.4	Mounting the horizontal track	9
5.5	Suspension	9
5.6	Mounting the C-track (>3000 mm)	10
5.7	Mounting the lintel seal	10
5.8	Mounting the end bearing plates	10
5.9	Mounting the shaft and springs	11
5.10	Mounting the panels	14
5.10.1	Choice of Hinges	14
5.10.2	Pre-mounting the bottom panel	14
5.10.3	Pre-mounting the intermediate panels	15
5.10.4	Placing the panel	15
5.10.5	Placing the top panel	16
5.11	Mounting the cable and positioning the cable drum	16
5.12	Stretching the torsion springs	17
5.13	Correcting the spring tension	17
5.14	Operating	18
5.14.1	Manual operator	18
5.14.2	Electrical operator	18
5.14.2.1	Adjustig the door operator	18
5.15	Affixing the CE-ID plate (sticker)	18
6	Technical data	18
7	First use	18
8	Trouble Shooter	19
9	Dismounting	20
10	The manufacturer	20
Annex A	Hinges / Panels survey	21
Annex B	Power drives	22
Annex C	EC declaration of conformity	23

1. Symbols and warning signs



General symbol for DANGER !!
Symbol for ATTENTION !!
Carefully read the text with this symbol!!



Symbol: Risk of physical injury!!
Carefully read the text with this symbol!!

2. General warnings



This manual has been prepared for use by qualified personnel and therefore not by trainees or “do it yourselfers”
In case of doubt about the assembly and/or maintenance, please contact DOCO International.



To avoid severe personal injury, carefully read and observe all indications and warnings in this manual.

- This manual describes the assembly and disassembly of residential set of fittings LF 220; this may be supplemented by other manuals, for instance the door operator manual (if applicable.)
- Your set of fittings has been designed according to the latest European standards; however you have to check yourself whether this standard corresponds with the local national standard.
- Adding or leaving out parts can affect the working and therefore the safety of the eventual sectional door and is therefore strongly discouraged!
- All indications concerning the assembly the mounting right / left are always viewed from the assembly location, that is from the inside to the outside!
- All measures are in millimetres unless otherwise specified.
- Check after the assembly whether the CE marking has been completed and attached.
- Keep this manual in a safe place.
- Subject to technical changes, without written notice.

2.1 Safety requirements for assembly and first use.



- The garage door may only be mounted, connected and put into operation by qualified personnel.
- Make sure that the power is switched off and remains switched off while electrical work is carried out!
- Never bridge safety devices !
- Some parts contain sharp edges: use protective gloves.
- Never use the sectional door in case of visual damage on the safety devices.
- When performing assembly/maintenance, always wear at least gloves and safety boots and during drilling wear safety goggles!
- Make sure that you can always perform your work in a stable environment.
- Secure the assembly/maintenance site with safety ribbon to keep others (children!) at a distance.
- Maintenance must only be performed by a qualified company and/or qualified personnel.
- Make sure there is enough light.
- Only use appropriate tools, especially when tensioning the torsion springs.



3. Directives and standards

For the design, production and mounting of these rail sets the following directives and standards have been used:

98/79/EEC	Machine Directive
89/106/EEC	Construction Products Directive (EN 13241-1)
89/336/EEC	EMC Directive
EN 12604	Mechanical aspects; requirements and classification
EN 12605	Mechanical aspects; test methods
EN 12445	Safety for power operated doors; test methods
EN 12453	Safety for power operated doors; requirements
EN 12978	Safety devices for power operated doors, test methods and classification
EN 12426	Air Permeability, test methods
EN 12427	Air Permeability; requirements and classification
EN 12425	Water tightness; requirements and classification
EN 12489	Water tightness, test methods
EN 12424	Resistance to Wind Load; requirements and classification
EN 12444	Resistance to Wind Load, test methods
EN 12428	Thermal Resistance.

This set of fittings complies with the abovementioned standards and directives.

The conformity has been proven. The documents concerned are available at DOCO International.

You find the Declaration of Conformity under paragraph 12.2 of this manual.

3.1 Guarantee and liability

Unprofessional assembly, any changes made to the garage door or changes in the door operator that do not comply with this manual will annul the guarantee and liability.

This also applies to damage caused by incorrect operation, failure to observe the instructions in this manual and/or poor maintenance or care.

4. Application + testing

DOCO International has developed a set of fittings for installation in garages in the private sector

Complies with the CE standard only if used with DOCO International parts.

This manual describes the assembly of a complete residential garage door exclusively equipped with DOCO-International parts. The mounting of parts not mentioned or described in this manual is the responsibility of the end manufacturer of the garage door, who is also responsible for a correct CE certification of the residential garage door.

DOCO International had the "Product Test" of this set of fittings carried out by the institute TÜV Nord cert in Germany, known as Notified Body No. 0032.

Documents of this "ITT" are available from DOCO upon request.



This "ITT" does NOT include a pass door. If you want to install a pass door, a separate Product Test must be carried out. This is the responsibility of the garage door manufacturer.

Class conform EN 13241-1 : see Annex C

5 Assembly



This set of fittings does not include the mounting material needed to mount this rail set on walls and/or the ceiling! It is the responsibility of the installer to check whether the construction of the mounting place is strong enough to support this garage door. The installer is also responsible for choosing the appropriate fixing materials for the foundation (stone, concrete, steel, wood).

5.1. Preparation of the assembly

- Check if the place where you want to mount the rail set is level and if the construction of the mounting place is strong enough to support this rail set. If not: reinforce
- Before you start the assembly, check if the garage has the required dimensions (*figure 1*).

W = Clear width
 H = Clear height
 OH = Upper space
 Z = Lateral space
 D = Built-in depth

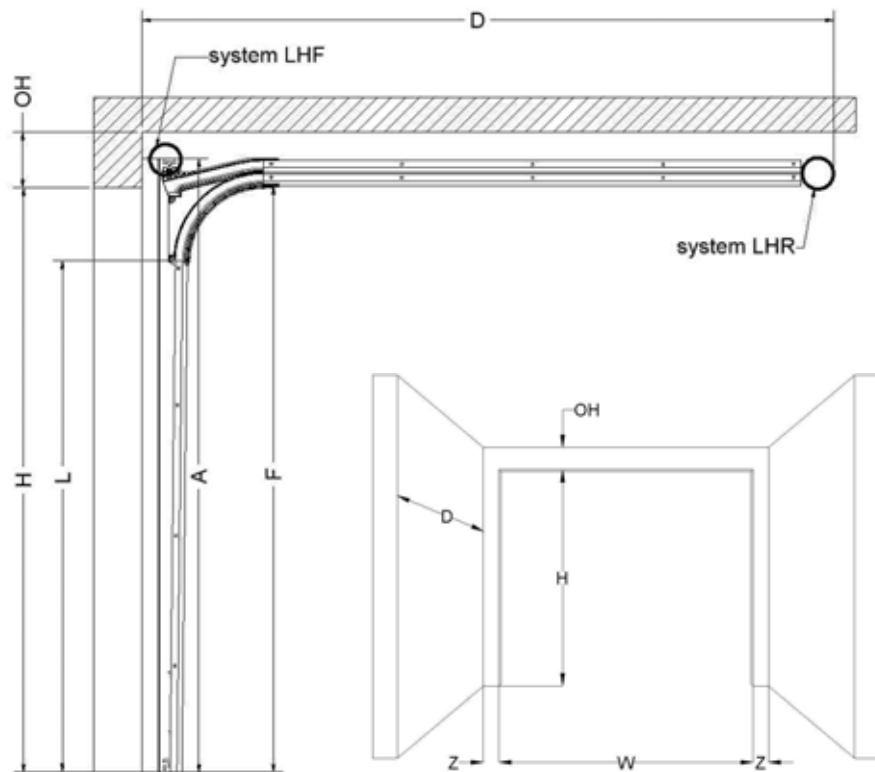

System LHF		OH = 210					
Vertical angle	Max Height (H)	A	L	F	Z**	D with 20226 rail***	D with 20270 rail***
23699*	2120	H+110	=H-300	=H	80	2708	3148
23698	2560	H+110	=H-300	=H	80	X	3148
23697	2850	H+110	=H-300	=H	80		3148

* Only use the 20182 track as vertical track in combination with 23699 vertical angle

** With reinforcement angle 24602 ⇒ Z=164 mm

*** Dimensions excluding door operator.

5.2 Mounting materials and instructions

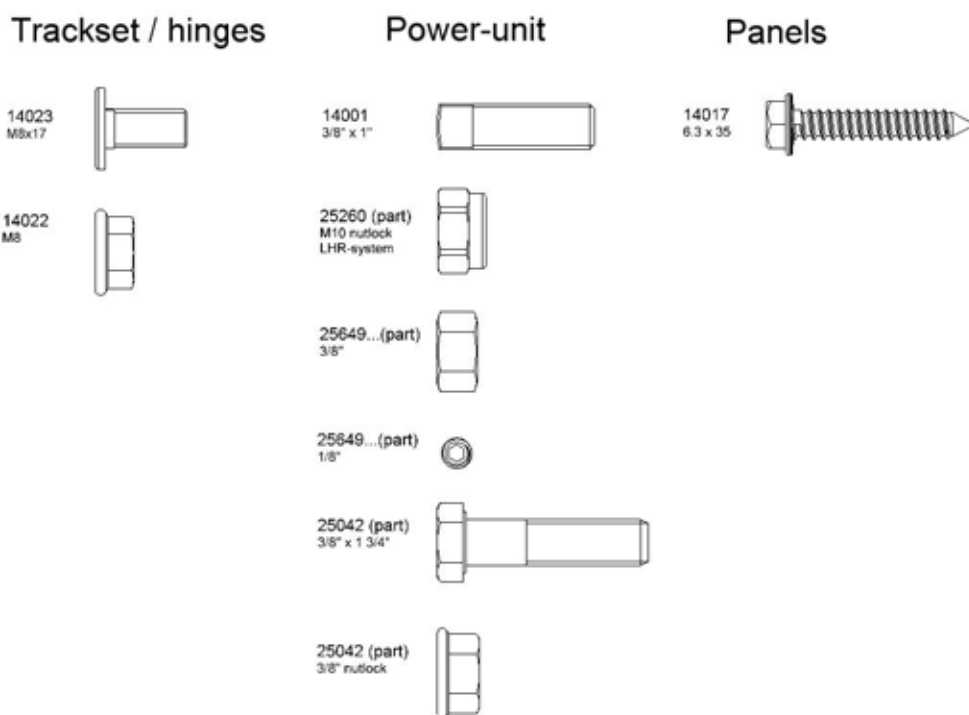

Description	Mounting material	Quantity	Torque (Nm)
Vertical angle (23699) and vertical track (20182)	14022	8x	20
	14023	8x	20
Vertical angle (23699) and plastic curve (24718)	14022	8x	20
	14023	8x	20
Vertical track (20226) and connecting plate (24602)	14022	8x	20
	14023	8x	20
Vertical track (20226) and plastic curve (24718)	14022	4x	20
	14023	4x	20
Vertical angle (23699) and end bearing plate (13022 / 13018)	14022	4x	20
	14023	4x	20
Bracket (24809) and suspension profile (24807)	14022	4x	20
	14023	4x	20
Vertical track (20226) with angle plate (24621)	14022	2x	20
	14023	2x	20
Angle plate (24621) with mounting plate (24620)	14022	2x	20
	14023	2x	20
End bearing plate (13022) and spring break device (25649...)	14022	4x	20
	14023	4x	20
End bearing plate (13018 / 13022) and bearing supports (13026/27)	14022	4x	15
	14023	4x	15

Description	Mounting material	Quantity	Torque (Nm)
Spring break device (25649...) and spring plug (12002 S /12003 S)	Nut 3/8"	4x	...
Spring break device (25649...) and ratchet wheel (25649...)	Hexagon socket screw 1/8"	4x	10
Spring plug (12002 W / 12003 W) and shaft (25018 / 25016)	14001	4x	34
Cable drum (11000 /11001 / 11014) and shaft (25018 / 25016)	14001	4x	34
Cable drum (11001 / 11014) and cable (25111-...)	Bolt 3/8"-16UNC-1 1/4" spec.	2x	18
Coupler (25042) with shaft (25016 /25018) / key (25064 / 25073)	14001	4x	34
Coupler (25042) between the two halves	Bolt 3/8"-16UNC-1 3/4"	3	34
	Nut plastic ring 3/8"-16UNC	3	34
Coupler (25034) and shaft (25016 /25018) / key (25064 / 25073)	14001	3x	34
Bottom bracket (25029) and panel	14017	12x	15
Side hinges and panel (per side hinge)	14017	6x	12
Roller carrier and basis side hinge (per hinge)	14022	2x	15
	14023	2x	15
Intermediate hinges and panel (per intermediate hinge)	14017	4x	10
Top roller carrier (25046 / 25043) and panel	14017	4x	10
Top roller carrier (25046) and adjustable bracket (25046)	14022	2x	18
	14023	2x	18

5.2.1 Assembly tools and attachments

You need the following tools for assembly:

- Water level (hose)
- (Battery) drill; with bit 10 mm for parkers.
- Open/Ring ended spanner: 10 mm / 13mm / 3/8" (spring break device)
- Hexagon key wrenches: 1/8" (spring break device)
- Pinchers: 3 (at least 2)
- Metal saw (for non-standard overall dimensions)
- Approx. 5 m of rope



**When drilling always wear safety goggles!
Use a stable and safe ladder!**

5.3 Mounting vertical angles and curves

We use as an example a garage door with the dimensions 2500 x 2120; this set does not require any sawing or drilling! For the assembly of doors with other dimensions, see **

Mark the wall with a line (1).
Mark a line (2) with a level.
For the floor alignment, mark lines (3) and (4) on the floor.

**** Vertical angle size = H (clear height) + 110 mm**

Mount seal (24740) on vertical angle (23699)
Mount both vertical angles against the wall with the bottom sides parallel to point (3) and (4); make sure that both angles are parallel and level in both directions. Secure at least in 3 places per side to the wall.
Subsequently mount curve (24718) on the vertical angle (23699) with 4x lock bolts (14023) en 4x flange nuts (14022).
Take rail (20182) and slide it into the curve (24718) up to the stop.

**** Length vertical rail = H (clear height) – 300 mm**

Slide the vertical rail (20182) into curve (24718) and then mark the bottom offset (depending on the panel thickness). Mark this bottom offset (panel thickness) in relation to the vertical angle and fix the vertical rail with at least 3 lock bolts (14023) and flange nuts (14022).

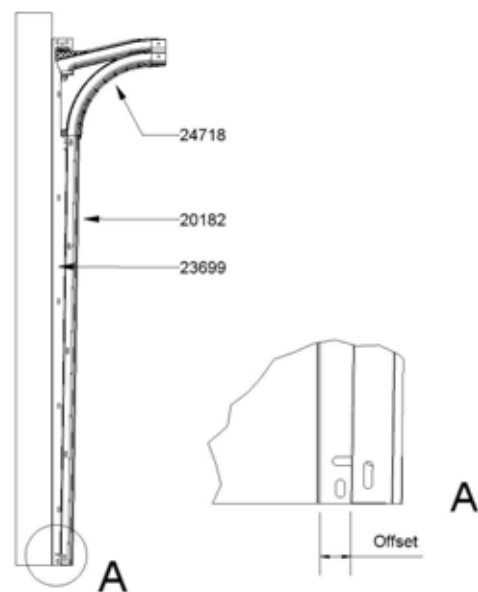
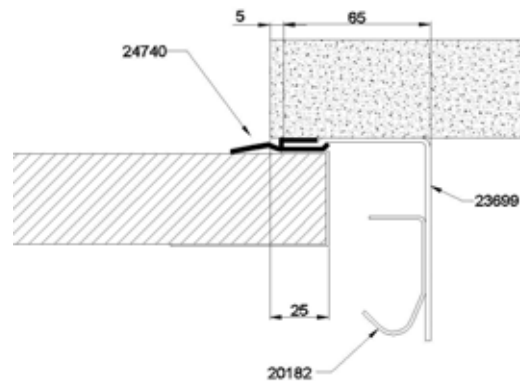
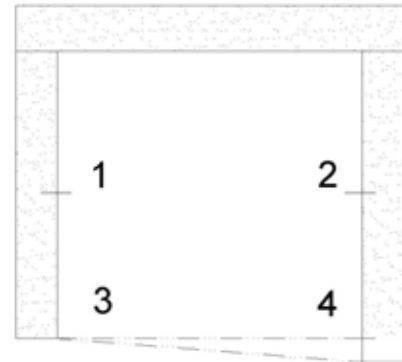

5.4 Assembling the horizontal rail

Mount both rails (20226) to each other with the rail connecting plate (24604) and the lock bolts (14023) and flange nuts (14022).
 Check the mounting positions!
 See figure on the right

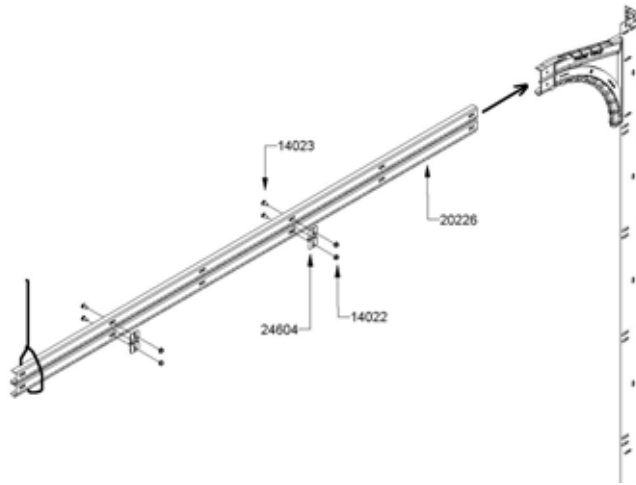

Fix a piece of rope to the ceiling or roof construction to keep the back of the rails up so that the horizontal rails are easy to mount.
 Now slide the connected rails in the plastic curve (24718) and secure with lock bolts (14023) and flange nuts (14022)
 See figure on the right

5.5 Suspension

Take 2 brackets (24809) and click them on the mounted horizontal tracks, one bracket (24809) on the synthetic curve (24718) and one on the end of the horizontal track set.
 Then slide the brackets (24809) under the joisting or roof construction and mount braces (24807 or 24805 with/without extension profile (24806) on the horizontal part of the rail set.
 Then mount the suspension brackets (24807 or 24805) on the ceiling, using 2 fixing devices* per mounting position.
 Untie the rope.
 See figure on the right

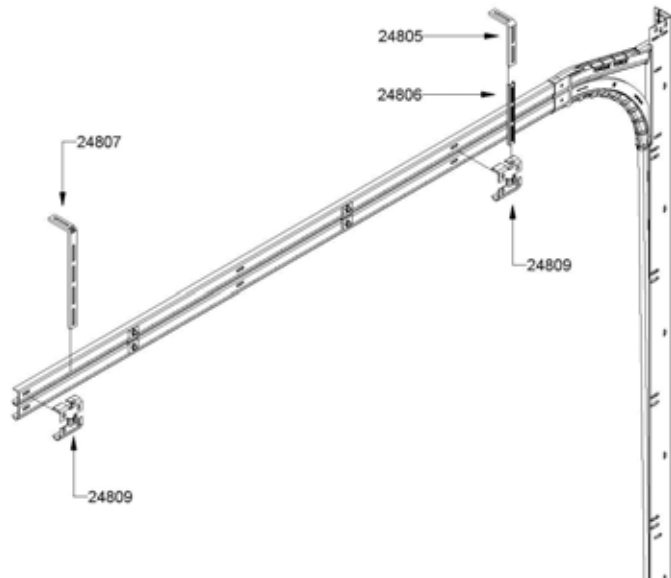

This set of fittings does not include the mounting material necessary to mount this rail set on walls and/or the ceiling! It is the responsibility of the installer to check whether the construction of the mounting position is strong enough to support the garage door. The installer is also responsible for the appropriate fixing materials for the foundation (stone, concrete, steel, wood.)

Now carefully check the following:

The horizontal parts of the rail set must be at right angles to the wall surface, where angle X = 90 degrees.
 Measure sizes C and D and check if they are equal. If not: correct the suspension .
 Then measure sizes A and B - they must also be equal. If not: adjust.
 Your rail set is now aligned.
 See figure on the right

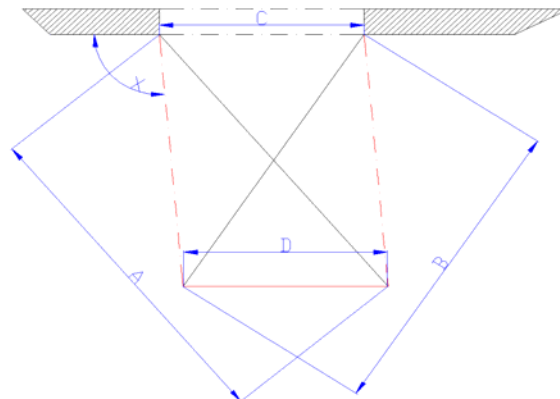

5.6 Mounting the C rail (if applicable)

Sectional doors wider than 3000 mm require a C-rail (24860 or 24127) that must be mounted between the two horizontal rail sets.

Mount the C-rail (24860 or 24127) to the corner plate (24621) using a mounting plate (24620) with lock bolt (14023) and nut (14022).

See the figures below.

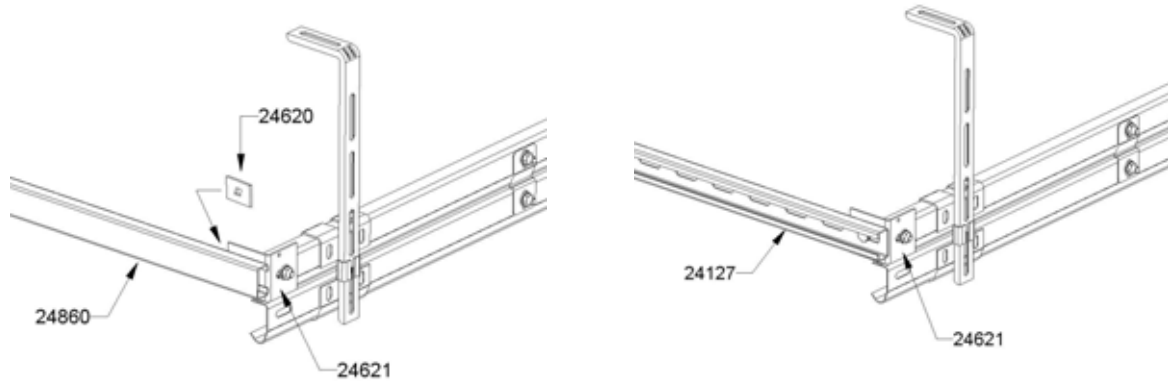

5.7 Mounting the lintel seal

Slide the sealing rubber (24740 or 24250/550) over the sealing profile (24710).

Mount the sealing profile (24710) against the lintel on the length of the clear width

Mount the sealing profile (24710) at 60 mm above the lintel.

Attention! : maximum overlap top panel: 15 mm

See figure on the right

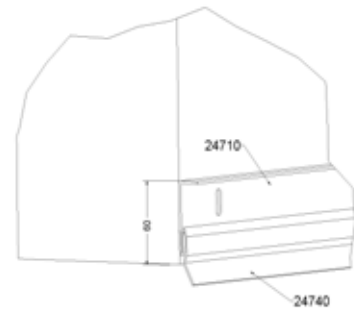

Note:



If a different lintel seal is used, the classifications obtained from the CE tests are void.

5.8 Mounting the end bearing plates

Before mounting the shaft with springs, you must first mount the brackets (13018 or 13022) onto the vertical angles (23699). Mount the bracket (13018 or 13022) with 2 lock bolts (14023) and flange nuts (14022) to the vertical angle (23699). We recommend to reinforce the fixation of the bracket to the wall / lintel. (be careful with the cable drum!) See the figures below.

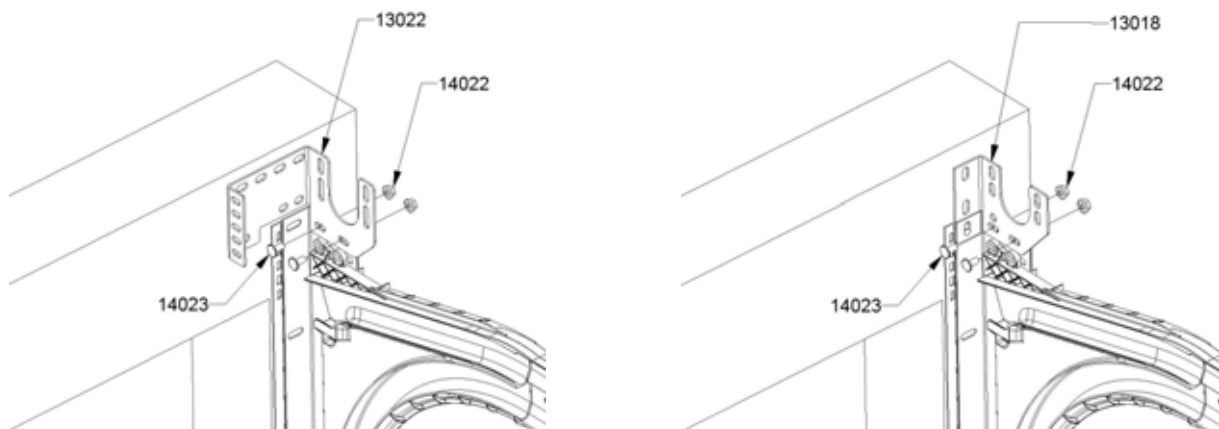

5.9 Mounting the shaft and springs

Door size: width < 3000 mm with 13022 end bearing plate

Slide cable drum (11000,11001,11014), spring breakage protective device (25649L/R50U or 25649L/R67U) and the mounted springs on the hollow shaft with key way (25018) as shown in the figure below.

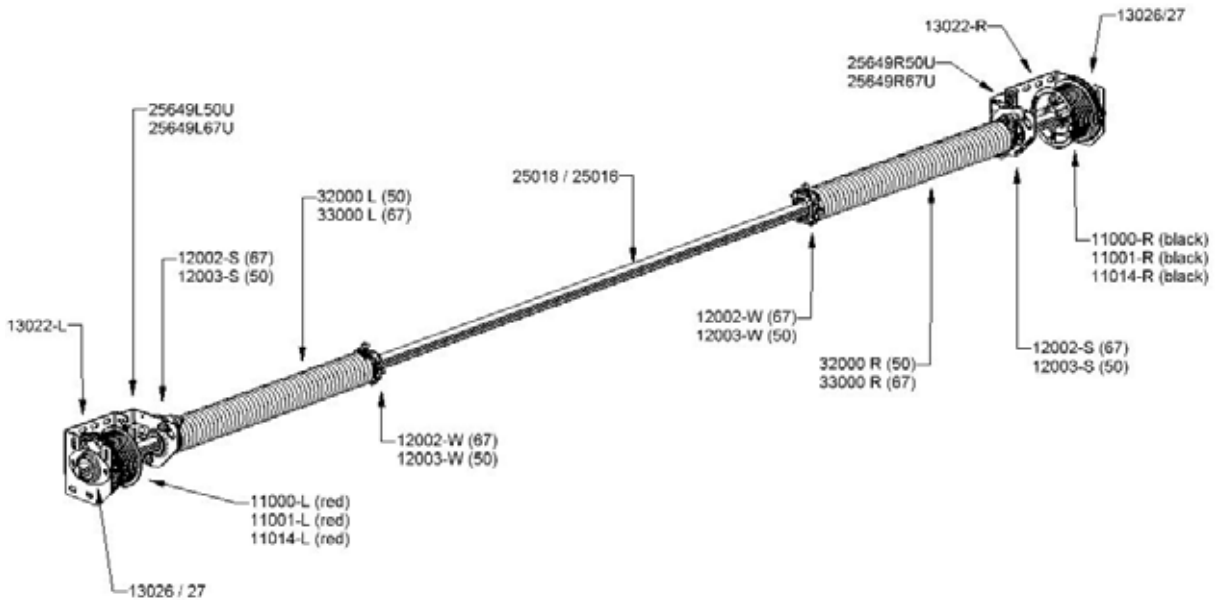

Door size: width > 3000 mm < 5000 mm with 13022 end bearing plate

Slide the cable drum (11001 ,11014), spring breakage protective device (25649L/R50U or 25649L/R67U), intermediate bearing plates (13023L/R) and mounted springs on the keyed shaft (25018) as shown in the figure below.

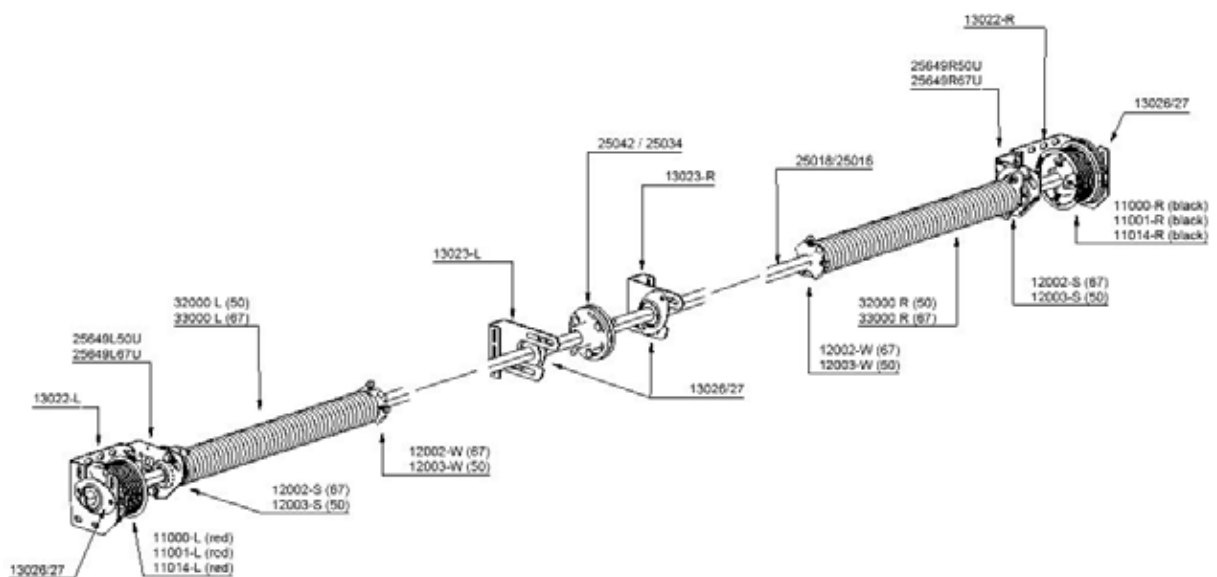

Then place the entire power unit in the brackets (13022L/R) - make sure that the bearing supports (13026/27) are located outside the brackets (13022). Mount the bearing holders (13026/27) to the brackets (13022) with 2 lock bolts (14023) and flange nuts (14022). Now mount the spring breakage safety devices* (25649-50 / 25649-67) to the brackets (13022) with 2 lock bolts (14023) and flange nuts (14022). Also make sure that the shaft (25018) is level. Make sure the lock bolts are mounted correctly.



See the figures below.

* See the separate enclosed manual of the spring breakage safety devices (25649-50 / 25649-67)

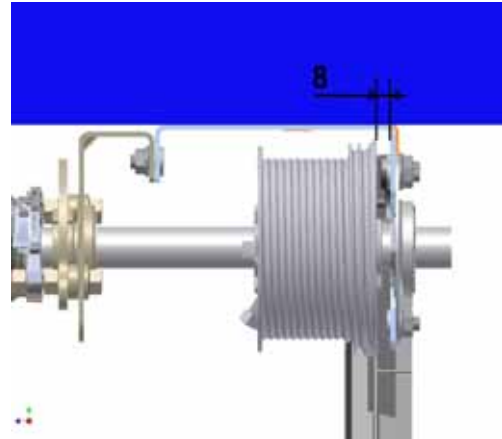
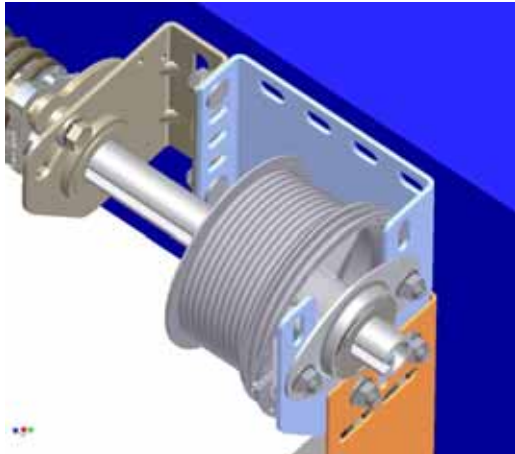

Door size: width < 3000 mm with 13018 end bearing plate

Slide cable drum (11001 1101411000), spring breakage safety device (25649L/R50U or 25649L/R67U) and the mounted springs on the hollow shaft with key way (25018) as shown in the figure below.

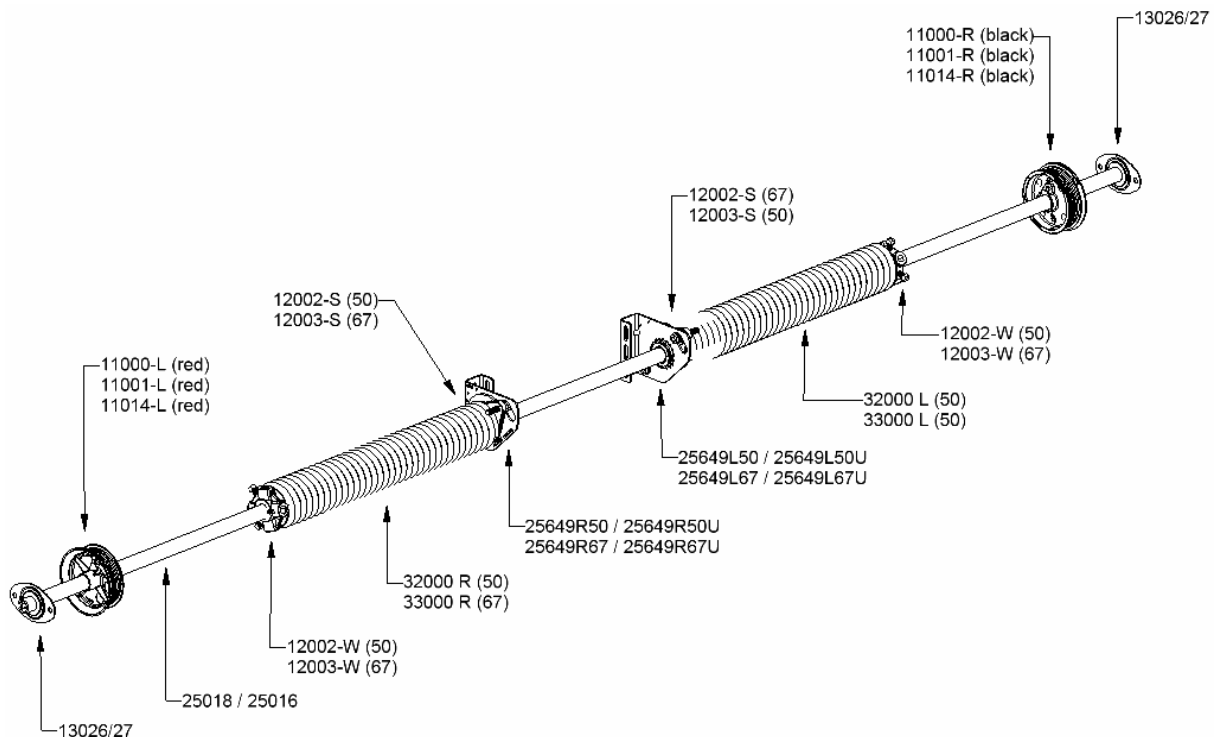

Door size: width > 3000 mm < 5000 mm with 13018 end bearing plate

Slide the cable drum (11001, 11014), spring breakage safety device (25649L/R50U or 25649L/R67U), coupling (25034/25042L/R) and mounted springs on the hollow shaft with key way (25018) as shown in the figure below.

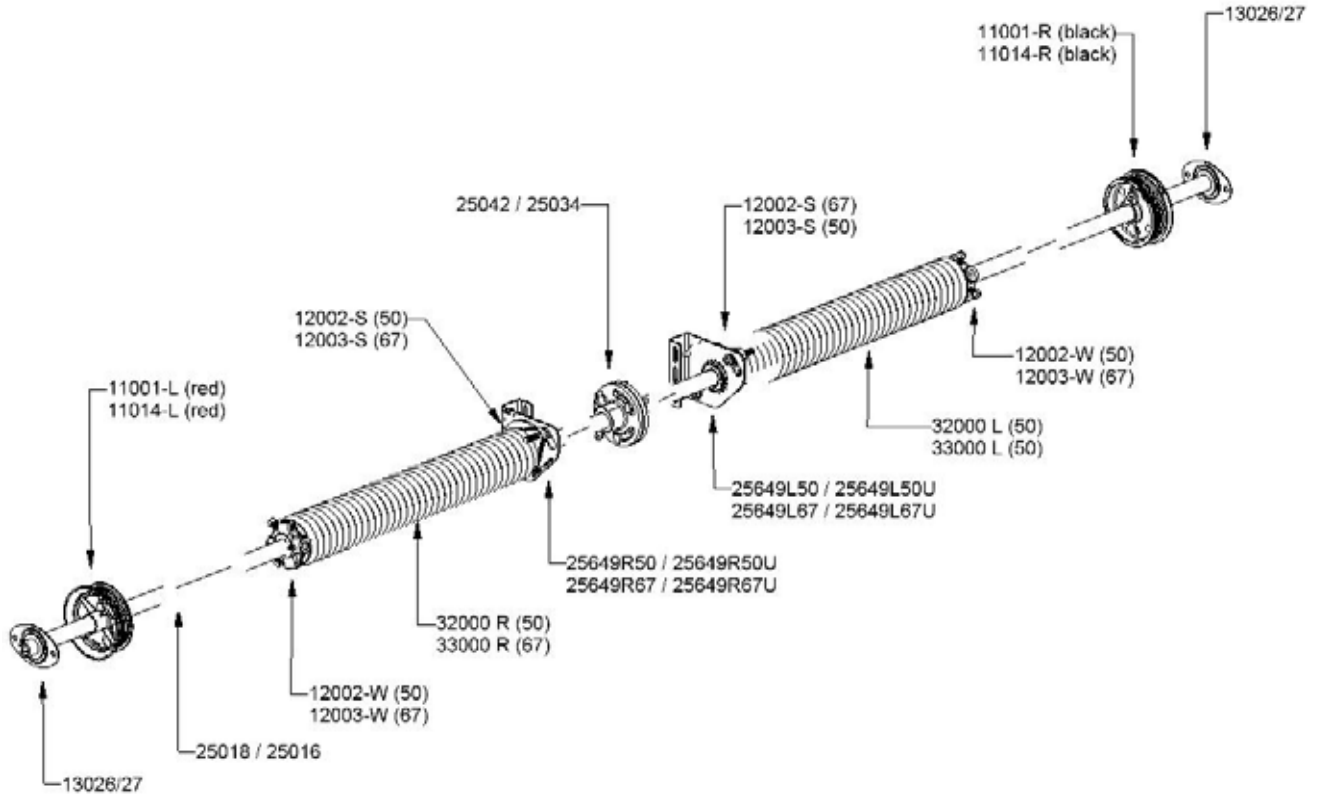

Subsequently place the entire power unit in the brackets (13022L/R) - make sure that the bearing supports (13026/27) are located outside the brackets (13022). Mount the bearing supports (13026/27) on the brackets (13022) with 2 lock bolts (14023) and flange nuts (14022). Now mount the spring breakage safety devices* (25649-50 / 25649-67) on the brackets (13022) with 2 lock bolts (14023) and flange nuts (14022). Also make sure that the shaft (25018) is level. Pay attention to the way the lock bolts are secured.



See the figures below.

* See separate enclosed manual of the spring breakage protective devices (25649-50 / 25649)

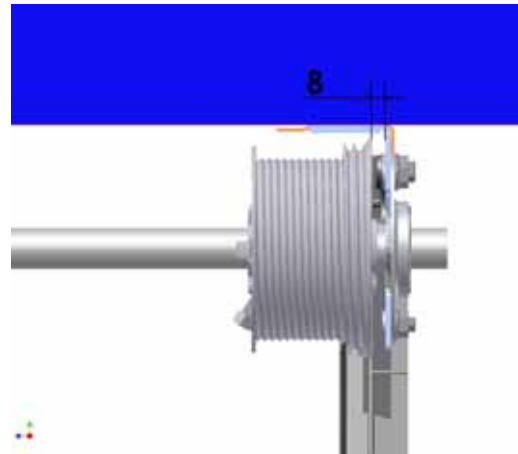
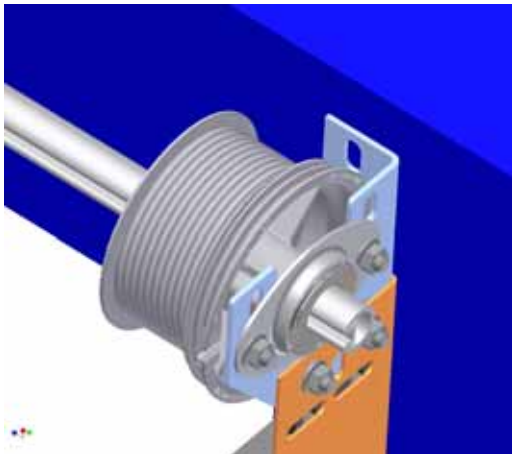

5.10 Mounting the panels

General:

Since our rail sets with hardware can be used with panels from different manufacturers, we give a general description for mounting the panel.



Always ask the manufacturer of your panel which additional measures, if any, are needed to guarantee the finger guard.

Generally, sandwich panels (steel plates with PUR foam) need pre-drilling with Ø 4.5 mm. However always check with the manufacturer of your panels which exact size you need for pre-drilling!

The entire door blade including aluminium profiles and bottom seal must have the following dimensions. See *figure on the right*

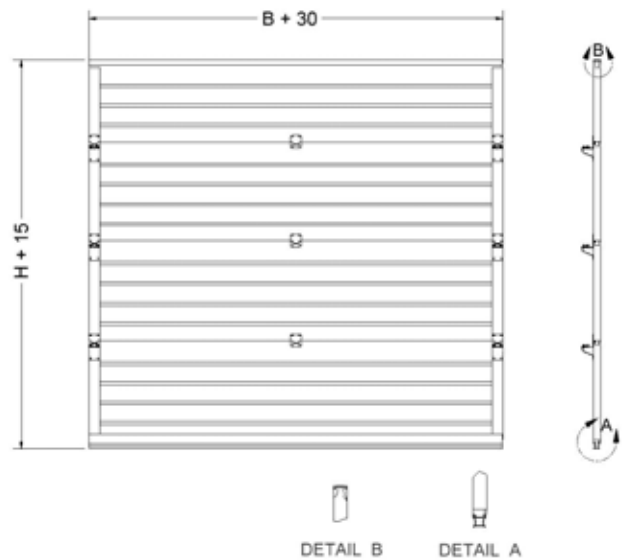

5.10.1 Hinges

Consult annex A for the right choice of hinges in combination with your panel.

The distance between the intermediate hinges needs to be equally divided over the length of the panel, see the table below.

Door width	Number of intermediate hinges
0-2749	1
2749-3999	2
3999-5000	3

5.10.2 Pre-mounting the bottom section



Important: NEVER shorten the bottom panel to determine the total height of the door blade; always shorten the top panel!

- Saw the panel (1) to the right length.
- Mount the end caps (2) on the panel (1) using blind rivets.
- Slide the aluminium profile (5) along the entire length of the panel (1) and secure it with blind rivets. Slide the sealing rubber on the aluminium profile.

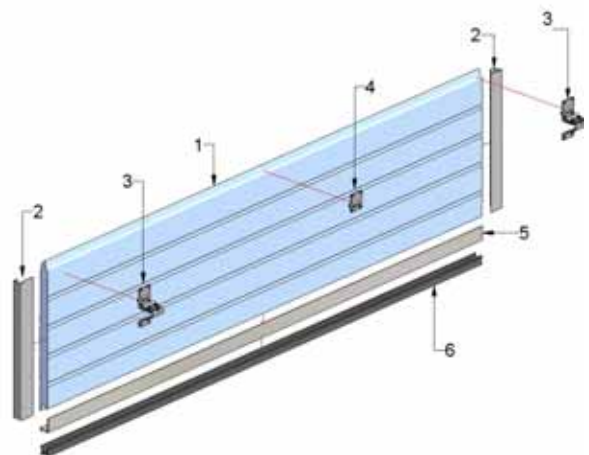

- Mount the bottom bracket 25029. *See figure on bottom left.*
- Mount the side and intermediate hinges. *See figure below and on bottom right.*

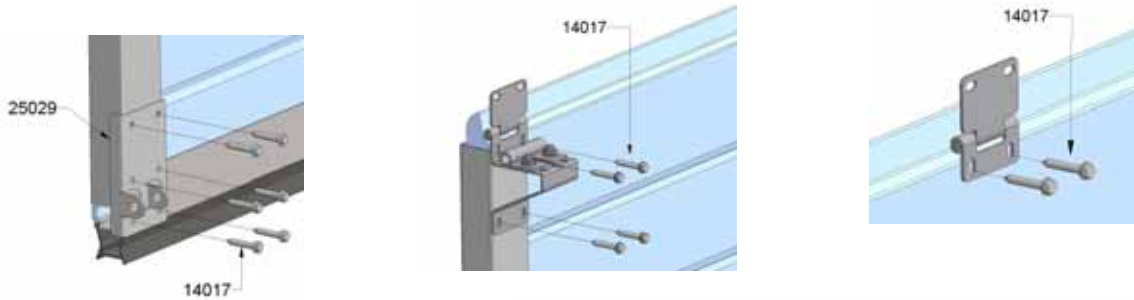

5.10.3 Pre-mounting the intermediate sections

Mount the intermediate sections as shown in the figure on the right.

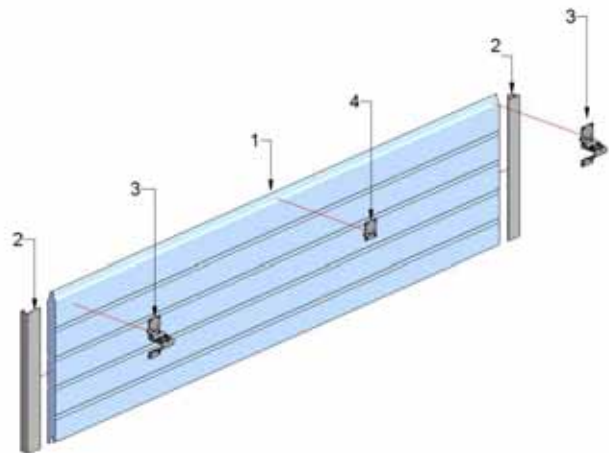

5.10.4 Placing the panels

- Place the floor section between the vertical angles. Make sure it is level!
- Take roller (25010-E / 25008) and finger guard (25700) with spacers (25632/25630) and cable set (25111-3) and slide these in the bottom bracket (25029). *See the figure on the right.*
- Do not forget spacer 25630! or you may risk damaging the cable set.
- Place the intermediate sections on the bottom sections and connect them with the hinges. Adjust the nylon rollers in such a way that the plastic tread lies in the rounding of the rail and that the play between panel and side seal (24740) is reduced to a minimum. You should be able to turn the plastic with your hand.
- Before mounting the rollers, slide the finger guards (25700) over the front of the rollers.
- Attention! once mounted, these finger guards can no longer be removed!
- Also pay attention to the mounting - see figure on the right.

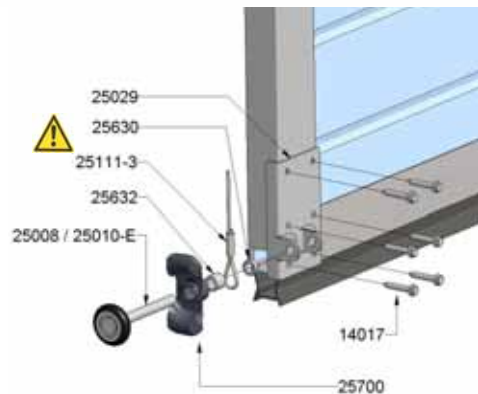

5.10.5 Placing the top panel

- Saw the top panel at the correct height.
- With an electrically operated garage door: use the adjustable top roller carrier (25046) or (25043).
- With a manually operated garage door: use the adjustable top carrier holder (25046).

Pay attention to the following:

- The roller of the top roller carrier (25043 / 25046) must remain under all circumstances on the tread of the curved track; if this is not the case, use spacers (25630-25632) to fill the space. If you are using a top roller carrier (25046), the play between end cap and the adjustable bracket of the top roller carrier must not exceed 4 mm.
- When closed, the roller of top roller carrier (25043 /25046) must lie against the tread of the curved track, but there should be no strain on either one of these parts.
- **Do not mount a finger guard (25700) on the top roller carrier!**

See the figures below.

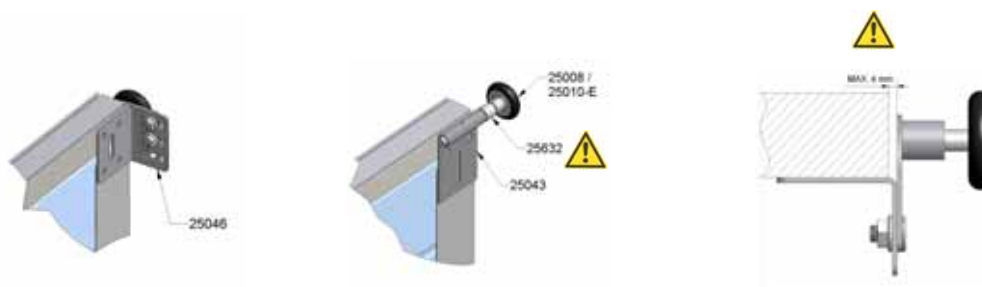

- Place the top section on the intermediate sections and position the top roller carrier according to figure

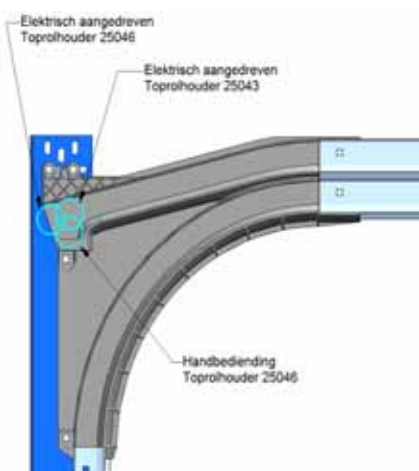

5.11 Mounting the cable and positioning the cable drum

- Level the shaft.
- Lead the cable (25111-3) of the bottom bracket (25029) behind the shafts of the roller to the cable drum (assuming a 11001-11014 cable drum is being used)
- Slide the cable end through the cable fixing hole of the cable drum (11001-11014) and turn the cable drum in such a way that the cable is tensioned and that there is at least cable of 1/2 a winding** on the drum; then mount the key (25064-25073) between shaft (25018-25016) and cable drum (11001 -11014). See figure on the right



** Equals 2 TÜV approved windings // Ref TÜV : BB-FTA-MUC/re-sc 30604_Besch_torque.doc

- Align the cable drum (11001-11014) in such a way that it is possible to freely wind up the cable (25111-..). Secure the cable drum (11001-11014) with the fixing bolts on the shaft between 27 – maximum 34 Nm.
- The cable fixing bolt must be tightened with 13 Nm.



Now block the shaft using the pinchers and secure the other cable the same way.
It is important that both cables are equally tensioned and that the door blade is balanced.

5.12 Stretching the torsion springs



Secure the door in such a way that it cannot go up. Fix the vertical tracks for instance with pinchers.
Tension the springs according to the following procedure.
The required number of turns of the spring is indicated on the labels of the assembled springs.
After tensioning, fix the spring fittings on the shaft with 27 up to 34 Nm (this applies both to spring fitting 12002-W and to spring fitting 12003-W.)

Procedure for stretching a spring.



IMPORTANT: There is much strain on tensioned springs; proceed carefully at all times, especially when performing corrective maintenance, and use tensioning bars that fit well and that are kept in good condition (12025)

Stretch the springs from the bottom to the top! Because of the stretching the spring becomes thinner and longer (number of turns x wire thickness); if this is not the case, the left and right spring have been switched!



- 1) Mark the spring with a straight line.
- 2) Insert the first tensioning bar in the tension head.
- 3) Turn the first tensioning bar a quarter of a turn to stretch the spring.
- 4) Hold the first tensioning bar and place the second bar in the next hole of the spring fitting.
- 5) Turn the second a quarter of a turn.
- 6) Hold the second tensioning bar (takes over the tension) and remove the first bar
- 7) Repeat steps 3 – 4 – 5 – 6 until the correct tension has been reached.
- 8) Secure the spring fitting on the shaft by turning both bolts of the fitting with 27 up to 34 Nm.
- 9) Now remove the second tensioning bar
- 10) Check the number of turns that the spring has made by counting the number of lines on the spring.

Remove the block of the shaft and the vertical tracks and your sectional door is ready.
Check if the door is well balanced. If not, then check item .. (correction of the spring tension).

5.13 Correcting the spring tension



Block the shaft and the door blade
Secure the door so that it cannot go up. Do so for instance by fastening pinchers on the vertical tracks.



IMPORTANT: There is much strain on tensioned springs; proceed carefully at all times, especially when performing corrective maintenance, and use tensioning bar that fit well and that are kept in good condition (12025)

You can correct the tension by stretching or releasing the spring with 1 full turn at the most. Make sure that both springs are equally corrected.

- 1) Insert the first tensioning bar in the tension head.
- 2) Turn the tensioning bar in the appropriate direction.
- 3) Carefully loosen the bolts of the spring fitting and take over the spring tension.

- 4) Hold the first tensioning bar and place the second bar in the next hole of the spring fitting.
- 5) Turn the second tensioning bar a quarter of a turn in the desired direction.
- 6) Hold the second tensioning bar (takes over the tension) and remove the first bar
- 7) Repeat steps 4 - 5 - 6 until the correct tension has been reached.
- 8) Secure the spring fitting on the shaft by turning both bolts of the spring fitting with 27 up to 34 Nm.
- 9) Now remove the second bar.

Remove the blocking of the shaft and the vertical tracks and your sectional door is ready.

5.14 Operating

The operating of your sectional door can be as follows:

- 1) Manually
- 2) Electrical operator

5.14.1 Manually

Mount the handle (25407/25403) on the bottom section

5.14.2 Electrical operator

Mount the operator according to the instructions of its' manufacturer .

Attention!

In case of electrical disconnection one must be able to open the door by an emergency handle. The door can then be opened or closed manually.

The door may only be operated by a handle.

The handle must be mounted in the centre of the door.

If a second exit in the garage is missing, a disconnecting device must be mounted (art. 60011).



5.14.2.1 Adjusting the door operator

The door operator must be adjusted according the manual of the door operator.

It is stressed once again that this set of fittings is only TÜV / CE certified in combination with door operators complying with Annex B. If a different door operator is used, other than the door operators prescribed in Annex B, the force measurements according to EN 12445/ EN 12453 must be performed again!



5.15 Placing the CE-ID plate (sticker)

Now place the CE sticker (art 80310 NL / FR) on the left or on the right side under an end cap of the second section.

See figure



6 Technical data

LF 220 system with synthetic curve and front torsion springs

- Width: max. 5000 mm
- Height : max. 3000 mm
- Door surface: max 11 m²
- Door weight: max 162 kg
- Build in space : 220 mm
- Sound pressure : <70 dBa
- Temperature range : -20° up to + 40° C
- Environment influence conform EN 13241-1 : see Annex C

The minimum safety level for the protection of the closing side complies with the requirements of EN 12453 according to table 1

Force measurements performed according to EN 12445.

The measured values remained under the maximum values of this standard.

The dimensions can be consulted at Doco International bv.

7 First use

The garage door must be put into operation by an experienced installer.

The first use of the garage door must be registered. The person responsible for the installation must write the declaration of conformity and affix the CE sticker.

Affixing the CE-sticker means declaring that the conditions of the EN directives have been met.

8 Trouble Shooter

Points to be checked with a not well functioning/ not balanced door

- Check 1) Check the weight of the door
- Check 2) Did you receive the right type of drums?
- Check 3) Have the cable drums been mounted correctly?
Pay attention to the following (looking from inside to outside)
 - Left drum coded red and mounted on the left side?
 - Right drum coded black and mounted on the right side?
 - Does the cable run between construction/ wall and shaft?
 - Check the position of the cable entry
- Check 4) Check if the right torsion springs have been delivered and mounted
 - Check the wire diameter
 - Check the spring diameter
 - Check the length of the springs (excluding spring fittings)
- Check 5) Door being closed friction must not be too strong. One must be able to still move the rollers.
- Check 6) Are there no obstacles while opening/ closing the door?
- Check 7) Check the space between doorblade and tracks, which should be around 20 mm and the cable is not to get stuck at any place.
- Check 8) Are the rollers parallel in vertical and horizontal direction? Take measurement of distance and height.

9 Dismounting

General:

- Dismounting may only be carried out by qualified personnel.
- Make sure that only personnel taking care of the mounting/dismounting is present at the mounting place. Keep other persons at a distance, for example by using a safety ribbon
- When dismantling the device, make sure there is enough light.
- Make sure that you use the right tools to remove the tension of the springs and make sure you are standing firmly

Procedure:

Block the shaft with the pinchers.

Secure the door in such a way that it cannot come up. Do so for instance by fastening pinchers to the vertical tracks.

IMPORTANT: There is much strain on tensioned springs; proceed carefully at all times and use tensioner bars that fit well and that are kept in good condition (12025)

- 1) Insert the first tensioning bar in the spring fitting.
- 2) Keep the first tensioning bar firmly in your hands and carefully loosen the bolts on the spring fitting and take over the spring tension.
- 3) Now place the second tensioning bar in the next hole of the spring fitting and carefully release the spring. The spring is basically released from top to bottom.
- 4) Put the first tensioning bar back in the spring fitting and release.
- 5) Repeat steps 3 - 4 until the spring is released.
- 6) Repeat steps 1 - 4 with the other spring.
- 7) Loosen the bolts of the cable drums and remove the steel cables from the cable drums.
- 8) Dismount the shaft with springs
- 9) Loosen the bolts and nuts from the coupling of the synthetic curve with horizontal track.
- 10) Dismount the suspension and slide the horizontal track out of the plastic curve.
- 11) Dismount the panel sections from top to bottom by loosening the roller carriers and intermediate hinges.
- 12) Dismount the synthetic curve.
- 13) Dismount the vertical angle.

9.1 Removal



All parts of the garage door are easy to separate and to recycle.

Separate all elements after dismantling.

Note: The material is only recyclable if separated

Turn in the materials at the authority responsible for the treatment of separated materials.

10 Your Manufacturer

DOCO International b.v.

Nusterweg 96

6136 KV Sittard (NL)

Tel. +31 46-4200666

Fax. +31 46-4526894

E-mail : info@doco-international.com

Annex : A Hardware / Panels.

Panel (1)	Endcap (2)	Side hinge(3)	Intermediate hinge (4)	Alu.Profile (5) Top and bottom	Bottom seal (6)
Bremet Securwall	80612L (610) / 80617L (488)	25734	25733	80041	80042
Bremet Securwall	80612L (610) / 80617L (488)	25006 / 25007 *	25006 *	80041	80042
Bremet Securwall	80612L (610) / 80617L (488)	25162 / 25163	25733	80041	80042
Hoesch	80612L (610) / 80613L (488)	25334	25333	80041	80042
Tekla Teckentrup	118438 / 118449	109555 / 122292	109554	116261	109549
Apco - Kingspann	80612L (610) / 80617L (488)	25334	25333	80041	80042
Ryterna	80612L (610) / 80617L (488)	25634	25633	80041	80042
Corsaro&lisco					

* Max. 90 kg door weight and max. door width 3000 mm

Annex B Certified operators

Operator :	Type :	Max. door width
Sommer	Aperto 868 L(550N)	3500 mm
Sommer	Aperto 868 LX(800N)	5000 mm
Sommer	Duo 500S (500N)	3000 mm
Sommer	Duo 800SL (800N)	5000 mm
Marantec	Comfort 220 (500N)	3500 mm
Marantec	Comfort 250 (700N)	5000 mm

Annex C EC Declaration of conformity

EC MANUFACTURER DECLARATION / EC DECLARATION OF CONFORMITY

We hereby declare that the products described below conform to the relevant fundamental requirements of the applicable EU directives, both in its basic design and construction as well as in the version marketed by us (Inspection bodies: TÜV Nord Cert 0032 and SP 0402). This declaration will cease to be valid if any modifications are made to this product without our express approval or if a door operator or panel other than those indicated below or other products than those described by Doco-International are used.

Product Description

Manually or electrically driven sectional overhead door DOCO LF 70/220

Panels in finger-safe execution:

ThyssenKrupp Hoesch, Ryterna, Bremet, Apco/Kingspan, Tekla/Teckentrupp

Motors:

Marantec Comfort 220, 250, 252; Sommer Duo 500S, Duo 800 SL, Aperto 868L, 868 LX

Manufacturer:

Doco-International BV
Nusterweg 96
NL-6136 KV SITTARD (NL)
Tel. +31-46-4200666
Fax. +31-46-4526894

Relevant EU Directives applied:

- Machinery Directive 98/37/EC
- Construction Products Directive 89/106/EEC
- EMC Directive 89/336/EEC
- Low voltage Directive 73/23/EEC

Harmonised Standards applied:

- EN 13241-1 Doors - Product Standard, Part 1
- EN 12604 Doors - Mechanical aspects
- EN 12453 Safety in use of power operated doors - Requirements
- EN 12635 Doors - Installation and use
- EN 12978 Doors and gates - Safety devices